

# TITAN Light Truck

# Series T815

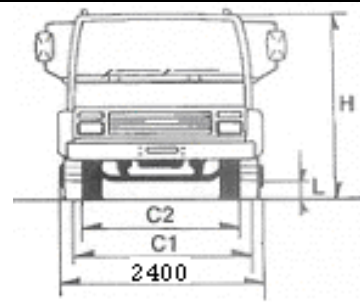
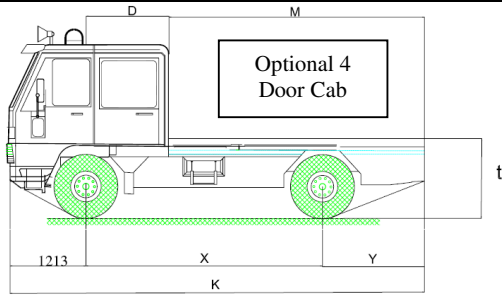

## DIMENSIONS (mm)

Wheelbase	X :	4400	3800	3300
Overall length	K :	6995	6995	5500
Overall height	H :	2510	2510	2510
Front track	C <sub>1</sub> :	1770	1770	1770
Rear track	C <sub>2</sub> :	1602	1602	1602
Rear overhang	Y :	1900	1699	800
Minimum ground clearance	L :	258	258	258
Turning circle radius.	:	8077	7115	5500
Angle of approach	$\alpha^1$ :	25°	25°	25°
Angle of departure	$\alpha^2$ :	18°	18°	18°

## WEIGHTS (kg)

Max. permitted GVW	:	8500.
Max. permitted at Front	:	2500
Max. permitted at Rear	:	6000
Kerb weight of chassis	:	2700

## ENGINE : Cummins EQB 140 – 20 (Euro2)

Aspiration :	Turbocharged & After cooled
Emission Level :	EURO 2 standard EURO 3 option
Diesel, Direct injection :	4 stroke
Number of cylinders :	4 in line
Bore :	102mm
Stroke :	120mm
Total Displacement :	3.9L
Max power output (SAE) :	156 HP at 2400 r.p.m
Max torque (SAE) :	502N.m@1500r/min
Air filter :	Dry type with cleanable element

## Performance

Engine Idle Speed	750±100r/min
Max.powered speed (kmph)	100
Max.gradeability (restart %)	30
Maximum altitude for continuous operation	3000m



Power Curve

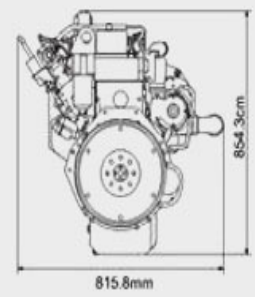
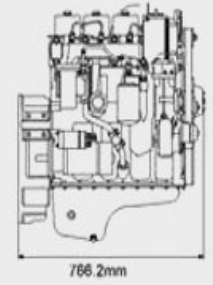
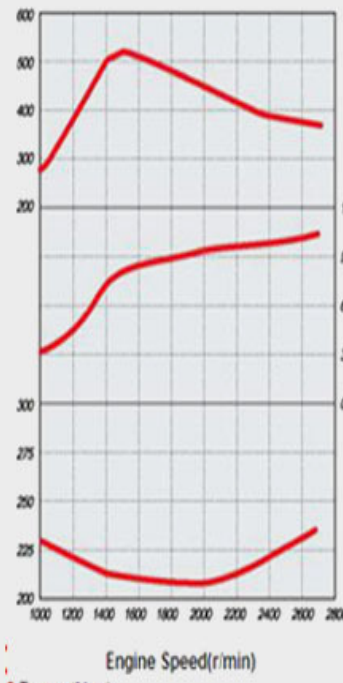

- Torque(N.m)
- Power(kW)
- BSFC(g/kWh)

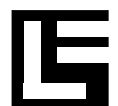

# TITAN 815

<p><b>CLUTCH</b> 350 mm dia. Non – asbestos single Plate, <b>SACHS</b> Dry type Diaphragm clutch, hydraulically actuate</p>	<p><b>LIGHTING AND INDICATORS</b> Head lamps, low beam, and high beam Direction indicators: front, side, rear Rear lights: direction, tail stop, reverses Roof marker lights</p>
<p><b>GEAR BOX</b> Synchromesh Z6 - 6S-120 Manual gear box <b>Fuller</b> Technology : No. of speeds 5 + 1 reverse : 5.160,2.808,1.594,1.000,0.756,R5.406</p>	<p><b>SUNDRIES</b> Pin type front vertical hook Spare wheel fitted with wheel carrier</p>
<p><b>CHASSIS FRAME</b> : All steel – Ladder type</p>	<p><b>CAB</b> All steel, short, forward control, manually tilt able (1<sup>st</sup> step 40°; 2<sup>nd</sup> step 50°) torsion bar assisted Cab suspension by 4 rubber bushes One piece, laminated windscreen Low positioned exterior door handles</p>
<p><b>Dimensions (mm)</b></p>	<p><b>Interior</b></p>
<p><b>Thickness longitudinal</b> : 6.35</p>	<ul style="list-style-type: none"> <li>• Adjustable driver seat.</li> <li>• Driver &amp; 2 seats</li> <li>• Safety belts</li> <li>• Manually operated wind-up windows</li> <li>• Fixed quarter vents</li> <li>• Kerb observation windows</li> <li>• Entry assist grab handle</li> <li>• Floor mat</li> <li>• Ceiling lamp</li> <li>• Sun visor</li> <li>• Glove compartment</li> <li>• Rear view mirror</li> </ul>
<p><b>Height longitudinal</b> : 229</p>	<p><b>Exterior</b></p>
<p><b>Width of webs</b> : 76</p>	<ul style="list-style-type: none"> <li>• Two electrically operated windscreen wipers</li> <li>• Front steel bumper</li> <li>• Access step</li> <li>• Mudguards and front grille</li> <li>• Radiator guard</li> <li>• External rearview mirrors</li> <li>• Front wind deflectors</li> </ul>
<p><b>STEERING</b> : Power assisted steering</p>	<p><b>Instruments</b></p>
<p><b>FRONT AXLE</b> : Forged, I section, Type <b>DANA or STYER</b></p>	<ul style="list-style-type: none"> <li>✦ Fuel level indicator + warning light</li> <li>✦ Engine coolant thermometer + warning light</li> <li>✦ Speedometer with odometer</li> <li>✦ Engine oil pressure gauge + warning light</li> <li>✦ Brakes air pressure gauge</li> <li>✦ Battery charge indicator</li> <li>✦ Key type ignition switch</li> <li>✦ Twin nozzle electric windscreen washer</li> </ul>
<p><b>REAR AXLE</b> : Fully floating, single speed, Hypoid Gear <b>DANA 60 SHO or STYER</b></p>	<p>✦ <b>Optional 4 door cabinet</b></p>
<p><b>Axle ratio</b> : 1 : 5.286 <b>ABS (Optional)</b></p>	<p><b>Fuel system consisting of:</b></p>
<p><b>SUSPENSION</b> : Semi-elliptic multi leaf Shackle Ended</p>	<ul style="list-style-type: none"> <li>• 120 lit fuel tank</li> <li>• Double fuel filter</li> <li>• Water separator</li> <li>• Jack, Tool set</li> </ul>
<p><b>Shock absorbers</b> : double acting, Hydraulic telescopic type At front.</p>	<p><b>Electrolab has the right to continuously develop and improve its products, and that requires changing specifications from time to time.</b></p>
<p><b>WHEELS</b> : 2 nos. in front and 4 nos. in rear. Rim Size B 6.5 / 16</p>	
<p><b>TYRES</b> : Size 8.25 R16 14 PR</p>	
<p><b>BRAKING SYSTEM</b> : Hydraulic dual circuit : (Optional) Full air pressure diaphragm operated on all wheels dual line circuit system</p>	
<p><b>Parking</b> : Pneumatically controlled on rear Wheels only. With Wabco ABS system : Extra Exhaust Brake &amp; Auto Slack</p>	
<p><b>ELECTRICAL SYSTEM</b></p>	
<p><b>Type</b> : 24 V negative earth</p>	
<p><b>Battery</b> : 90Amp. Hr. (20 Hr. rating)</p>	
<p><b>Alternator max output</b> : 55Amps</p>	
<p><b>Starter</b> : 24V 4.5 kw</p>	
	

## ELECTROLAB

Dallah building, 7 A Cornaish ELnil, Maadi, Cairo, Egypt Zip code : 11431  
Email: [electrolab@electrolabtrucks.com](mailto:electrolab@electrolabtrucks.com)

Tel : ++ (20)2 25285213 (14) (15) (16)

Fax ++ (20)2 25285212

Web Site: [www.electrolabtrucks.com](http://www.electrolabtrucks.com)