

- Two booms with telescopic stage mounted on chassis cabs with working basket.
- Used to maintain and repair lampposts and others.
- Boom structure built of high resistance steel.
- Can be equipped with quick connection hydraulic ports.

Technical specifications:

- Working height 28m.
- Basket capacity: 350kg.
- Size: 160 x 100 x100cm.
- Max. outreach 8-12m
- Steel rail cage.
- Rotation: 360°.
- Stability: 4 hydraulic outriggers
- Hand pump for emergency.
- Hydraulic gear pump directly mounted to truck engine.
- Dual control from ground and basket.
- Oil tank with capacity 80 lit equipped with strainer and temperature level gauge.
- Vertical position for the basket.
- Safety system during operation.
- Hydraulic Filter (10 micron)

Options:

Hydraulic ports

- Tool boxes.
- Insulation up to 60 K.V.
- Side or rear ladder.
- Oil pressure indicator.
- Steel structure basket.
- Hook with capacity (6) m. ton.
- Spraying unit (gun + compressor)
- Alarm against inclined platform.
- Lighting system on the basket.
- Electric power tape in the basket
- Continuous rotation.
- Shock absorber on the stand of the boom.
- Phosphoric orange color (the whole vehicle)
- Advertising washing unite.
- Rotating beacon for alarm.
- D.C emergency pump.
- Nozzle for washing electric insulators.

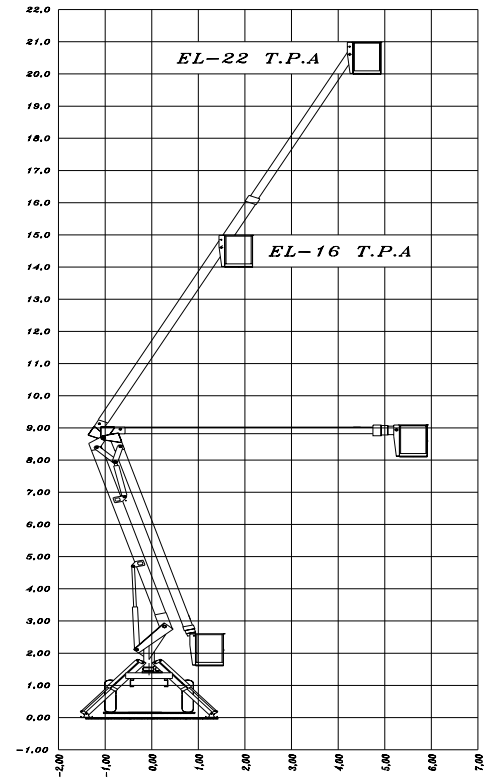

ELECTROLAB

212, Sudan St. Midan Lebanon Cairo – Egypt

www.electrolabtrucks.com

Tel.: ++20-2- 347 9769/ 347 4236

Fax: ++ 20-2-302 5791

Email:electrolab@electrolabtrucks.com