

Lift Truck (Basket)

Model EL 28 T.P

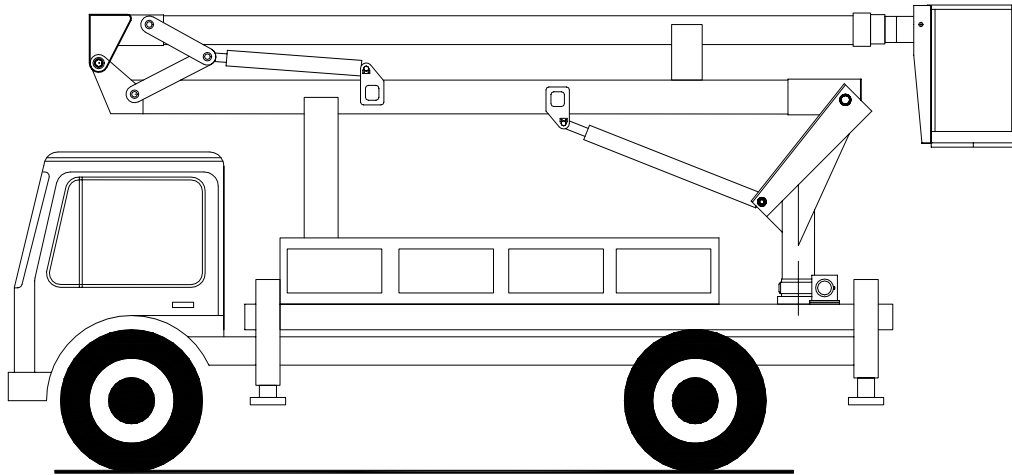

- Two booms with telescopic stage mounted on chassis cabs with working basket.
- Used to maintain and repair lampposts and others.
- Boom structure built of high resistance steel.
- Can be equipped with quick connection hydraulic ports.

Technical specifications:

- Working height 28m.
- Basket capacity: 350kg.
- Size: 160 x 100 x100cm.
- Max. outreach 8-12m
- Steel rail cage.
- Rotation: 360°.
- Stability: 4 hydraulic outriggers
- Hand pump for emergency.
- Hydraulic gear pump directly mounted to truck engine.
- Dual control from ground and basket.
- Oil tank with capacity 80 lit equipped with strainer and temperature level gauge.
- Vertical position for the basket.
- Safety system during operation.
- Hydraulic Filter (10 micron)

Options:

- Hook with capacity (6)m. ton.
- Spraying unit (gun + compressor)
- Alarm against inclined platform.
- Spot lights on the basket
- Shock absorber on the stand of the boom
- Fluorescent paint on the boom
- Water tank 1000 liter + water pump.
- Fiberglass basket (10kv).
- Continuous rotation.
- Rotating beacon for alarm.
- D.C emergency pump.
- Non-slip base plate.
- Side boxes.
- Side or rear ladder.
- Hydraulic ports.
- Electric ports (12 V).