

## Foam Tank for fire trucks

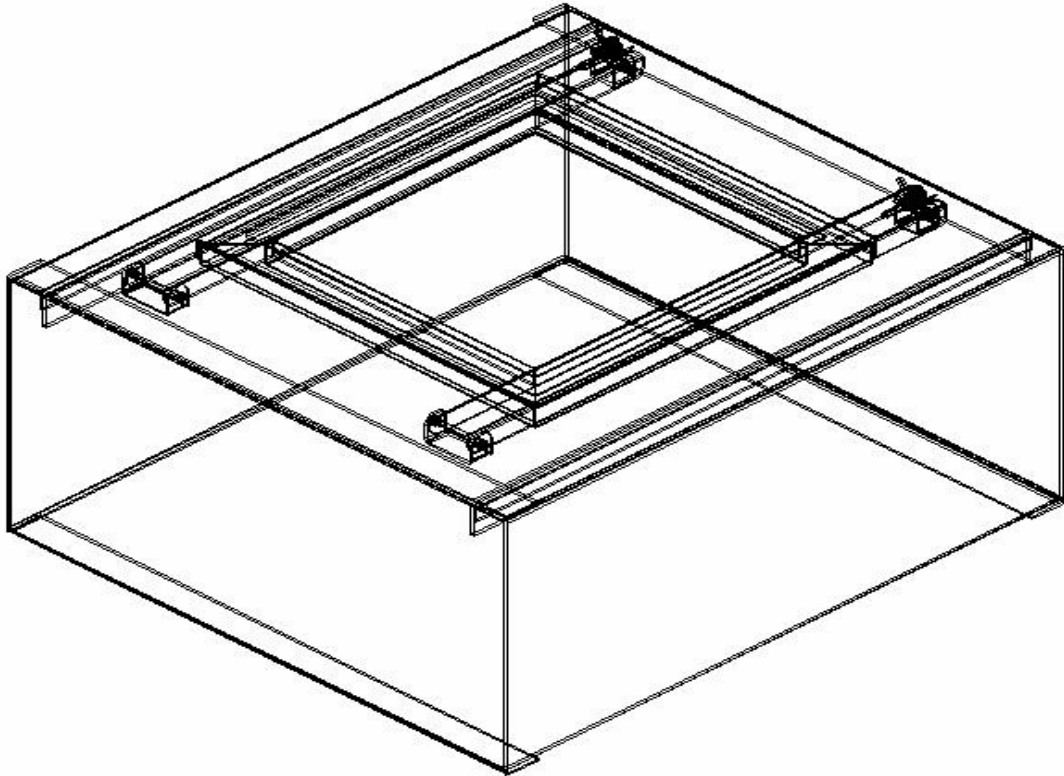

### Technical Specifications:

- The tank is in a parallelogram shape.
- Capacity upon customer's demand.
- Manufactured according to the NFPA standards.
- Internal baffles for breaking the inertia forces upon applying brakes or turning.
- Upper cover can be fully removed.
- Efficient use of space.
- The tank is designed and manufactured according to NFPA standards..
- Manufactured from stainless steel.
- Double treated welds.
- Low center of mass.
- Several support points on the sides of the vehicle depending on the size of the tank.
- Foam level indicator.